

Aeration Systems



Welcome to AGI AIRLANCO

Nation's Leading Name in Aeration



Dependable Performance

AIRLANCO makes dependable centrifugal and axial fans, ducting, transitions and other sheet metal and aeration products that are used daily across North America. AIRLANCO is constantly improving the fan and air duct designs to handle new and more demanding applications.

Combine Energy-Saving Aeration and Efficient Hazard-Free Unloading with AirAuger Systems

Empty bins safely and completely with AIRLANCO's dual-purpose AirAuger System. By combining pitched flooring, troughs that connect to exterior ductwork, precision perforated decking and proprietary AIRLANCO technology, AirAuger systems efficiently empties product that would otherwise bridge or get hung up in the storage unit. Fans, controls and all serviceable components are mounted outside the storage bin for safety.

Get Expert Design Assistance

AIRLANCO's experienced engineers, technicians and craftsmen create custom solutions for each installation. Unlike most suppliers of aeration equipment, AIRLANCO manufactures the components and provides the design expertise to assemble a complete line of aeration systems to meet any requirement. AIRLANCO will recommend the best and most cost-effective options based on the characteristics of the products employed and the storage conditions. AIRLANCO sales engineers will demonstrate the advantages of installing AIRLANCO® Aeration Systems or an AIRAUGER® System. Before building a new storage facility or upgrade an existing facility, call 800-500-9777 or 402-245-2325 for information.



System Design

AIRLANCO Aeration Systems are individually designed for each storage facility to maintain proper grain or seed temperature and moisture levels for the specified length of storage.

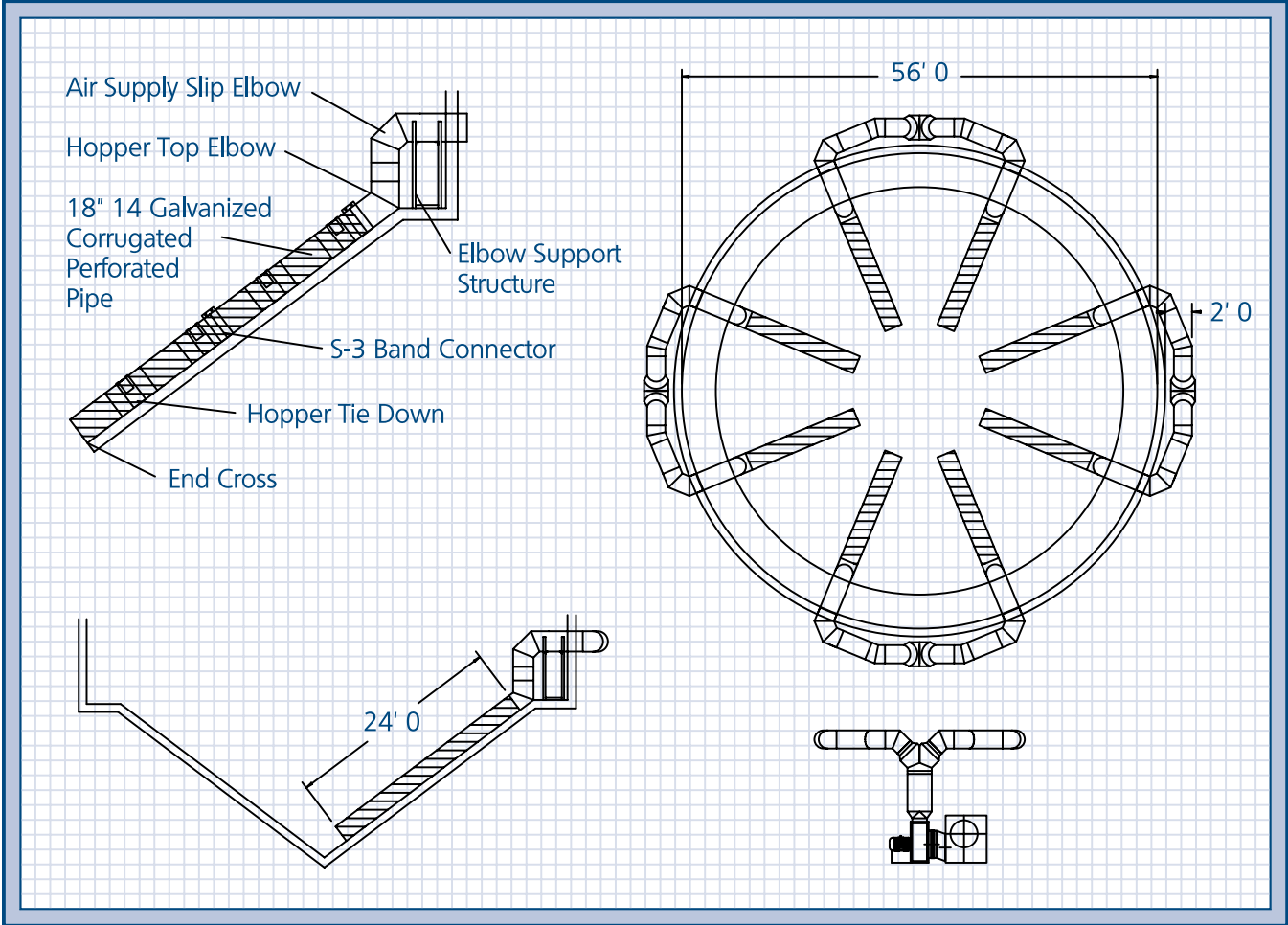



Centrifugal Fan

AIRLANCO Centrifugal Fans are ideal for installations involving temporary wet grain holding, deep storage and facilities where high static pressures are required. AIRLANCO's direct, rugged steel housings and non-overloading, vibration-proof fanwheels enhance performance and durability. Low-power consumption combined with generous air delivery result in low-cost and efficient aeration even under the most demanding conditions.



Axial Fans

AIRLANCO Axial Fans are engineered for efficient, high-volume air delivery where storage depth is low to medium. Axial airfoil propellers are cast in shatter resistant aluminum alloy. They are statically and dynamically balanced and secured to the motor shaft with a self-locking mechanism. Housings are constructed of heavy-gauge steel to exacting tolerances that allows for easy replacement of parts during service.



Tapered Roof Exhausters

Our Universal Tapered Roof Exhausters are designed to fit any sloped-roof or round metal bins without the need for special adapters. The removable top cover allows the user to position and bolt the units in place before cutting holes and permits easy service access. Available in a 24-inch, 2-hp model rated at 10,200 CFM.



Vertical Axial Roof Exhauster

AIRLANCO Vertical Axial Roof Exhausters are built for use on concrete tanks and can be installed on new or existing flat roofs. They are available in 24-inch, 2 hp and 40-inch, 5 hp models with 10,200 and 27,600 cfm ratings, respectively.

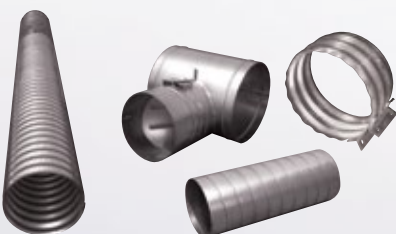

Manifolds & Aeration Accessories

AIRLANCO designs and manufactures the manifolds, transitions, pipes, fittings and all other accessories needed to build complete, custom-fitted aeration systems.

Replacement Parts & Service

Receive All Parts from One Source

AIRLANCO's Service and Parts department stocks a full range of service items and replacement parts for aeration equipment, receivers, bag dumps, blower packages, airlocks and bin vents. Fabric filters of many types and sizes, cages, cartridge filters, diaphragm valves and other replacement parts are also commonly in stock and ready for immediate shipment. Our inventory is stocked with AIRLANCO and equipment from other manufacturers including:

- Centrifugal Fans
- Axial Fans
- Flush Floor Systems
- Roof Exhausters
- Corrugated Pipe
- Manifold Systems
- Manifold Fittings
- Butterfly Valves
- Barrel-Type Silencers
- Elbow Silencers
- Vibration
- Dampeners
- Gravity Vents
- Shutters
- Ducts & Accessories
- Spiral Seam Pipe
- Saddle Tees
- Three-Piece Wyes
- Filter Bag
- Cages
- Cartridge Filters
- Airlocks
- Pneumatic Tubing
- Diaphragm Valves
- Solenoid Valves
- Timer Boards

Fast & Responsive Service

AIRLANCO will guarantee that our products meet equipment and timetable expectations. When quality parts, components and timely turnaround are needed, AIRLANCO customers can expect consistent responsive service.

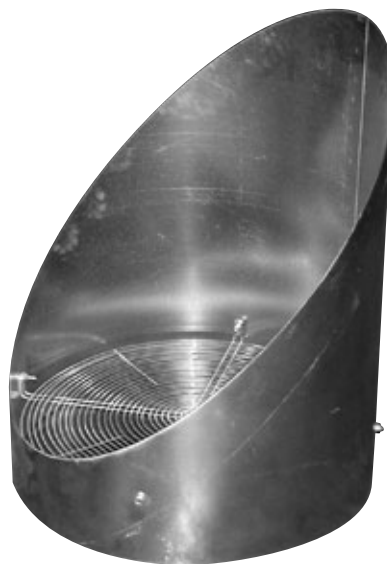

Leading the Field in Aeration, Unloading & Dust Control

With over 30 years of experience in the industry, AIRLANCO is the nation's leading designer and manufacturer of aeration and unloading components, equipment and dust control systems. AIRLANCO's dependable centrifugal and axial fans, roof exhausters, ducting, transitions, dust control and

other sheet metal and aeration products are in daily use at thousands of sites across North America, like farm storage and export terminals. AIRLANCO's standard components are made from heavy-gauge galvanized steel for extended service life and are customized for each installation.

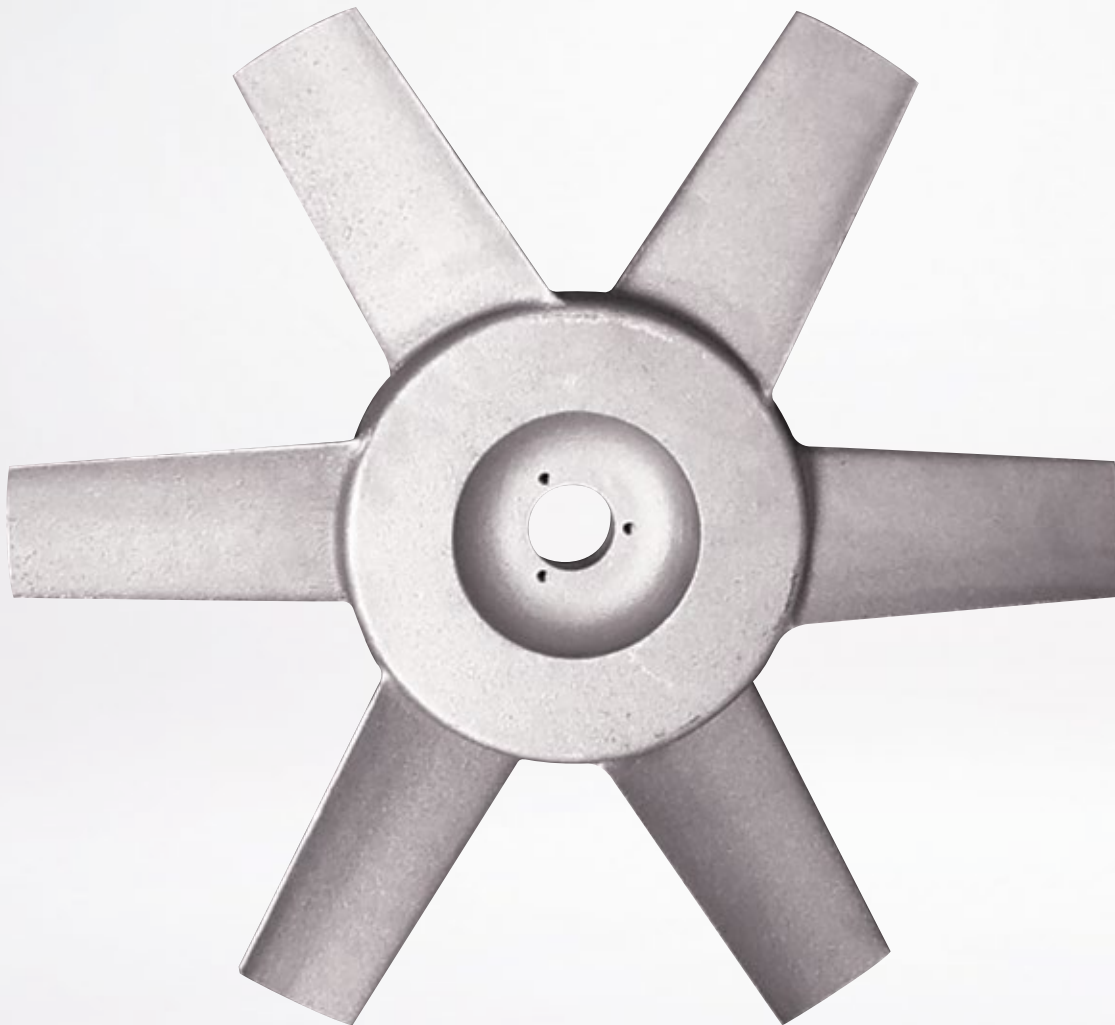



AIRLANCO is an AGI Brand.

AGI is a leading provider of equipment solutions for agriculture bulk commodities including seed, fertilizer, grain, and feed systems with a growing platform in providing equipment and solutions for food processing facilities. AGI has manufacturing facilities in Canada, the United States, the United Kingdom, Brazil, South Africa and Italy and distributes its products globally.

AGI AIRLANCO

312 South Highway 73, PO BOX 398, Falls City, Nebraska, USA 68355
 1.800.500.9777 | sales@airlanco.com | airlanco.com